

Specifications

MODELS	SLC™-12		SLC™-18		SLC™-24	
MEASUREMENTS	Metric	US	Metric	US	Metric	US
Working height:						
standard forks - forks down	3.40 m	11 ft 2 in	5.10 m	16 ft 9 in	6.78 m	22 ft 3 in
standard forks - forks up	3.94 m	12 ft 11 in	5.64 m	18 ft 6 in	7.32 m	24 ft
adjustable forks - forks down	3.40 m	11 ft 2 in	5.10 m	16 ft 9 in	6.78 m	22 ft 3 in
adjustable forks - forks up	3.94 m	12 ft 11 in	5.64 m	18 ft 6 in	7.32 m	24 ft
boom**	3.70 m	12 ft 2 in	5.41 m	17 ft 9 in	7.10 m	23 ft 3 in
A Height - stowed	2.18 m	7 ft 2 in	2.18 m	7 ft 2 in	2.18 m	7 ft 2 in
B Length - stowed	86 cm	2 ft 10 in	86 cm	2 ft 10 in	86 cm	2 ft 10 in
C - operating	1.60 m	5 ft 3 in	1.85 m	6 ft 1 in	2.06 m	6 ft 9 in
D Width - stowed*	80 cm	2 ft 7.5 in	80 cm	2 ft 7.5 in	80 cm	2 ft 7.5 in
- with stabilisers lowered	1.68 m	5 ft 6 in	1.68 m	5 ft 6 in	1.68 m	5 ft 6 in

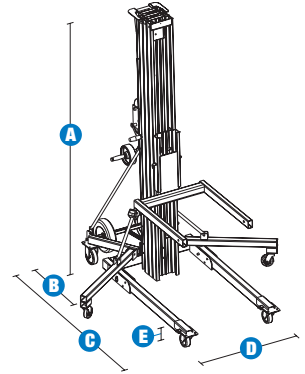

PRODUCTIVITY						
Load capacity:						
36 cm (14 in) load centre	295 kg	650 lbs	295 kg	650 lbs	295 kg	650 lbs
61 cm (24 in) load centre	193 kg	425 lbs	193 kg	425 lbs	193 kg	425 lbs
1.07 m (42 in) load centre	82 kg	180 lbs	73 kg	160 lbs	73 kg	160 lbs
E Ground clearance	5 cm	2 in	5 cm	2 in	5 cm	2 in
Load height minimum	15 cm	6 in	15 cm	6 in	15 cm	6 in

POWER						
Average cranks:						
standard winch	27.8 cranks/m	8.5 cranks/ft	27.8 cranks/m	8.5 cranks/ft	27.8 cranks/m	8.5 cranks/ft
two speed winch, high	13.1 cranks/m	4 cranks/ft	13.1 cranks/m	4 cranks/ft	13.1 cranks/m	4 cranks/ft
two speed winch, low	49.2 cranks/m	15 cranks/ft	49.2 cranks/m	15 cranks/ft	49.2 cranks/m	15 cranks/ft

WEIGHT						
	102 kg	225 lbs	139 kg	307 lbs	157 kg	347 lbs

LOAD HANDLING ATTACHMENTS						
MEASUREMENTS	Metric		US		Weight - Metric	Weight - US
Standard forks (l/w/d)***	71/58/6 cm	28/23/2.5 in			12 kg	26.5 lbs.
Adjustable forks (l/w/d)***	70/30-76/6 cm	27.5/12-30/2.5 in			24 kg	52.5 lbs.
Fork extensions detached (each) (l/w/d)***	76/5/8 cm	30/2/3 in			2 kg	4.5 lbs
Fork extensions attached (each) (l/w/d)***	64/5/8 cm	25/2/3 in			2 kg	4.5 lbs
Boom (l/w/d)***	46-107/4/15 cm	18-42/1.5/6 in			18 kg	39.9 lbs
Pipe cradle (l/w/d)***/*	69/61/15.2 cm	27/24/6 in			4.5 kg	10 lbs
Load platform (l/w/d)***	67/58/6 cm	26.3/23/2.5 in			14 kg	31.5 lbs

* Outside dimensions.
 ** Measured from ground to bottom of shackle.
 *** Length/Width/Depth.
 **** Handles round objects up to 76 cm (30 in) in diameter.

Features

EASILY CONFIGURED TO MEET YOUR NEEDS

PLATFORM OPTIONS

- Boom
- Standard forks
- Adjustable forks
- Fork extensions
- Pipe cradle
- Load platform

POWER OPTIONS

- One speed winch
- Two speed winch

BASE OPTIONS

- Standard base
- Stabiliser set

STANDARD FEATURES

MEASUREMENTS

SLC™-12

- 3.94 m (12 ft 11 in) maximum working height
- Up to 295 kg (650 lb) lift capacity

SLC™-18

- 5.64 m (18 ft 6 in) maximum working height
- Up to 295 kg (650 lb) lift capacity

SLC™-24

- 7.32 m (24 ft) maximum working height
- Up to 295 kg (650 lb) lift capacity

PRODUCTIVITY

- Standard forks
- Heavy-duty design
- Strong, lightweight aluminium telescoping mast
- Single door access
- Quick set up requires no tools
- Interchangeable load handling attachments
- Non-marking 10 cm (4 in) front casters and 13 cm (5 in) rear casters with side brakes
- Rear transport wheel assembly
- Glide rails allow easy loading and unloading, on or off a vehicle, for transport

STANDARD FEATURES cont.

PRODUCTIVITY cont.

- Hold-down bar secures mast assembly during transport
- Captive stabiliser set (standard on SLC™-18, -24)
- Mast brake

POWER

- One speed winch



OPTIONS & ACCESSORIES

PRODUCTIVITY

- Boom
- Adjustable forks
- Fork extensions
- Pipe cradle
- Load platform
- Stabiliser set (option on SLC™-12)
- Pneumatic rear transport wheel assembly

POWER

- Two speed winch

UK

The Maltings
Wharf Road
Grantham NG31 6BH
UK
Tel: +44 (0)1476 584333
Fax: +44 (0)1476 584334

France

10, ZA de la Croix St. Mathieu
28320 Gallardon
France
Tel: +33 (0)2 37 26 09 99
Fax: +33 (0)2 37 26 09 98

Germany

Finienweg 3
28832 Achim/Bremen
Germany
Tel: +49 (0)4202 8852-0
Fax: +49 (0)4202 8852-25

Spain

Gaià 31, Pol. Ind. Plá d'en Coll
08110 Montcada i Reixac
Barcelona
Spain
Tel: +34 93 572 50 90
Fax: +34 93 572 50 91

Scandinavia

Aröds industriväg 34
422 43 Hisings Backa
Sweden
Tel: +46 31 57 51 00
Fax: +46 31 57 51 04

Middle East

Terex Middle East
PO Box 282325, Dubai
U.A.E.
Tel: +971 4 885 8030
Fax: +971 4 885 6364
Email: awp.infome@terex.com

Genie United States

18340 NE 76th Street
P.O. Box 97030
Redmond, WA
USA 98073-9730
Tel: +1 425 881-1800
Fax: +1 425 883-3475

Email: AWP-InfoEurope@terex.com

Distributed By: